

# THOR Switchable Area Floodlights

Model	Wattage	VEET	IPART	Lumens	Colour	Warranty
LPTSF80-150	80   100   120   150	TBA	TBA	12,500   15,500   18,000   22,700 lm	4,000k	5 years *
LPTSF240-310	240   260   280   310	TBA	TBA	36,000   39,000   42,000   46,500 lm	4,000k	5 Years *

## Features & Benefits



- Ultra slim & light weight
- Switchable Fitting covering wattages 80 up to 310w over 2 units
- 10kVa surge protection
- Motion sensor and PE Cell accessory available
- 150 lumen per watt
- Up to 80% Energy savings
- Easy to install
- 2 different mounting types - NOT Included
- IK10 Rated
- Anti-corrosive aluminum
- Half and full Glare Shields available
- Excellent tennis court, flood and street lighting
- 5 year warranty period
- Brackets NOT included
- Asymmetrical beam angle
- SAA Approved.
- IP66 Rated

## Dimensions & Weight



Model	Fitting Length	Fitting Width	Spigot Connection	Net Weight
LPTSF240-310	340mm	300mm	<b>MUST ORDER</b> - Spigot / Trunnion	4.50kg
LPTSF240-310	510mm	300mm	<b>MUST ORDER</b> - Spigot / Trunnion	6.30kg

## Technical Specifications

Voltage AC120-277V	Wattage Mixed - See Above	Power Factor >0.95	Beam Angle ASym	Colour 4,000k	Life Cycle 56,000 Hrs
IP Rating IP66	VEET/ESS/REES TBA	CRI >80	Diffused Yes	Dimmable Yes - Standard	Heat Rating -30°c to +45°c

\* Please Note: Light Planet's warranty covers for defective products only. No incidentals like labor or hire cost shall be claimed from any party. Please read our T&C for further information.

# THOR Switchable Area Floodlights

## Mount Types & Fittings Dimensions

PART NO: LPSAFS  
Adjustable Spigot Bracket



Spigot Opening Max: 60mm  
Bracket length: 185mm

PART NO: LPSAFTM  
Adjustable Trunnion Mount



Bracket Width: 134mm  
Bracket length: 135mm

80 - 150w

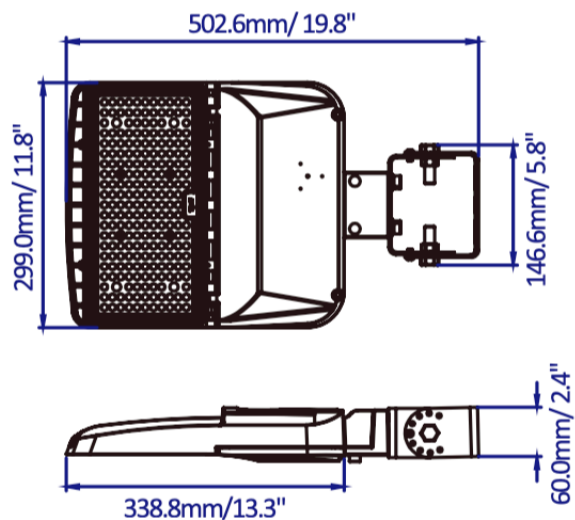

Net Weight: 4.4kgs/9.7Lbs

240 / 310w

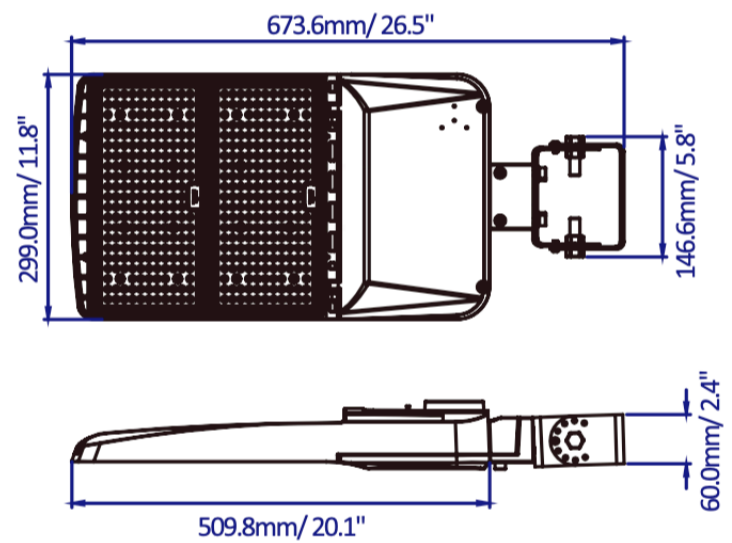

Net Weight: 6kgs/13.2Lbs

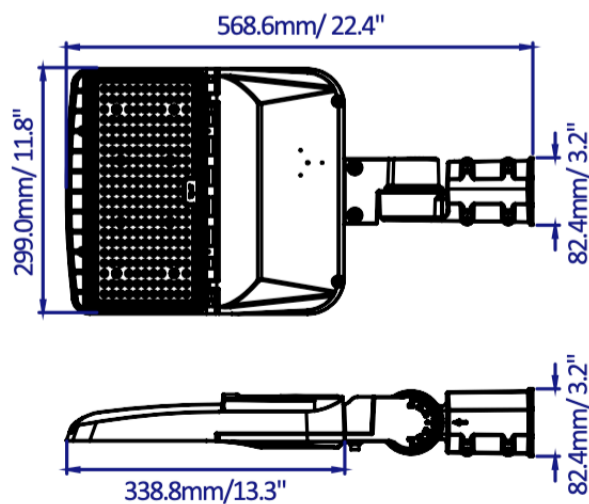

Net Weight: 4.6kgs/10.1Lbs

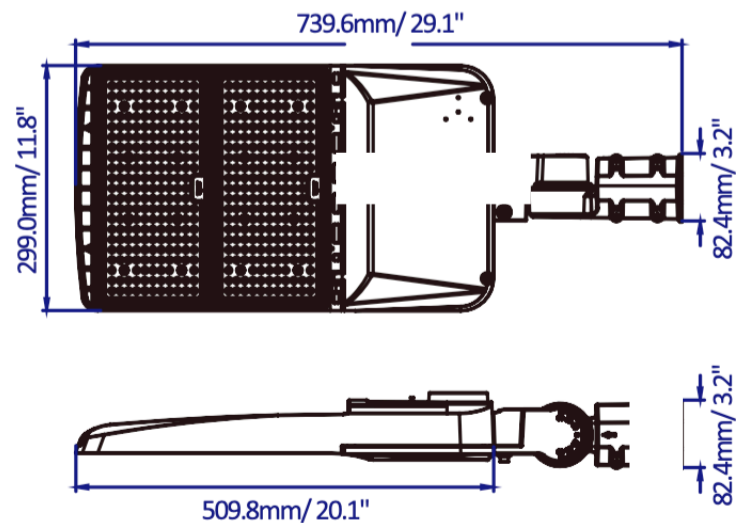

Net Weight: 6.2kgs/13.7Lbs

\* Please Note: Light Planet's warranty covers for defective products only. No incidentals like labor or hire cost shall be claimed from any party. Please read our T&C for further information.