

Apollo Flood Lights

Market Leading Product

| Model | Wattage | VEET | IPART | Lumens | Colour | Warranty |
|----------|---------|----------------|----------|--------|--------|----------|
| *LPF50W | 50 | Approved / NBB | Approved | 6,000 | 5,000k | 5 years |
| *LPF100W | 100 | Approved / NBB | Approved | 13,000 | 5,000k | 5 years |
| LPF150W | 150 | Approved / NBB | Approved | 19,500 | 5,000k | 5 years |
| LPF200W | 200 | Approved / NBB | Approved | 26,000 | 5,000k | 5 years |



Features & Benefits

- LED Flood Light
- MeanWell Driver
- Significant power savings
- Excellent heat dispensation
- IP65
- Plug top fitted
- Easy to install
- Extruded Aluminum body
- 50,000 average life hours
- Robust and sturdy design
- 5 year warranty
- Nichia chip base
- SMD chip set
- Available in 4 different sizes
- VEET Approved
- VEET NBB Approved
- ESC Approved

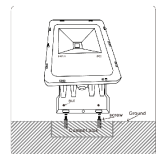
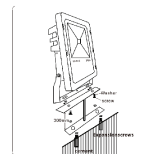
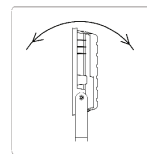
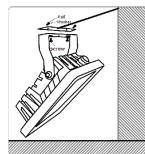

Technical Specifications

| | | | | | |
|-------------------------|---------------------------|-----------------------|--------------------|------------------|-------------------------------|
| Voltage AC100 - 277V | Wattage MIXED | Power Factor >0.95 | Beam Angle 120° | Colour 5,000K | Life Cycle 56,000+ |
| IP Rating IP65 | VEET/ESS/REES Approved | CRI >75 | Diffused No | Dimmable No | Heat Rating -25°c to +45°c |

* Please Note: Limited or no stock available. Please call to confirm ETA.

Apollo Flood Lights

Dimensions & Weights

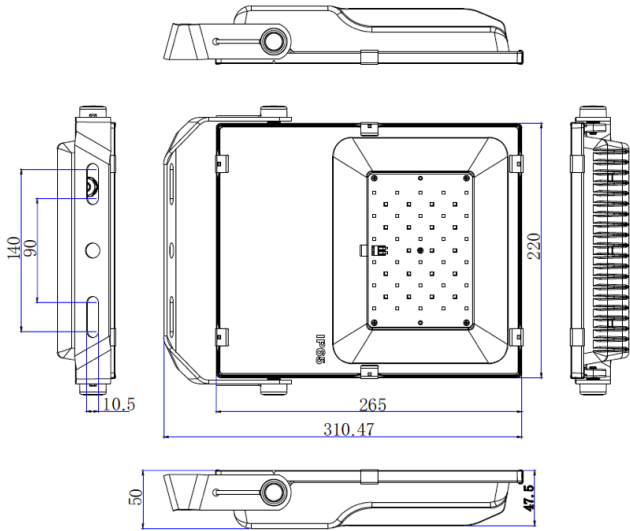

50W - 2.5kg's

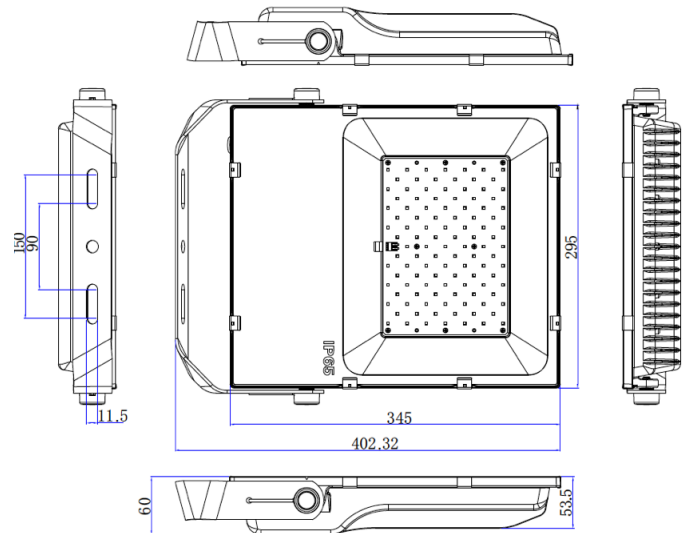

100W - 5.5kg's

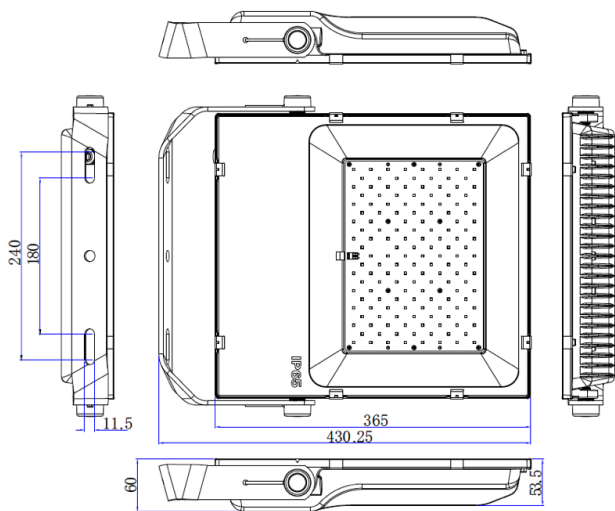

150W - 9.8kg's

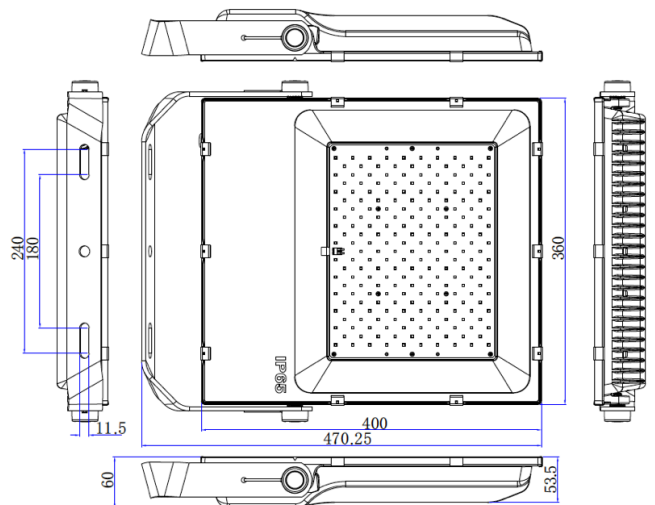

200W - 10Kg's